

## TECHNICIAN INSTRUCTIONS FOR KID-Dee-Lite™

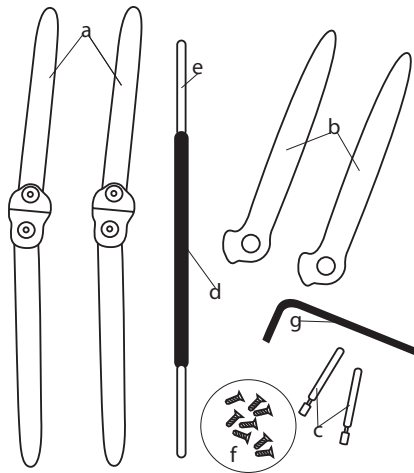

### Components included in a Kid-Dee-Lite™ Set:

- a. 2 assembled straight stainless steel joints (20° PF to 20° DF)
- b. 2 curved stainless steel proximal joint sections (0 to 50° PF OR 0 to 50° DF)
- c. 2 mounting pieces with hexagon screws
- d. 1 8cm alignment tube
- e. 1 5mm pin
- f. 8 screws (M3x6)
- g. 1 1.5mm allen wrench

The curved sections may be used to replace the straight components. Posterior positioning of the upright under the thermoplastic allows for heat adjustments to the tibial section of the orthosis during fit / delivery. A wider tooth also allows for greater flexibility in ROM settings, set by grinding the tooth to the desired size.

## Instructions for Thermoforming Over KID-Dee-Lite™

### I. Prepare the Negative

- Insert the 5mm pin through the ankle joint axis. Once satisfied with placement, cover pin with alignment tube and install into negative. The pin acts as reinforcement to the tube and maintains positioning while pouring the cast. Notches may be created with a saw blade or file to secure within plaster
- Insert vacuum pipe and pour as usual

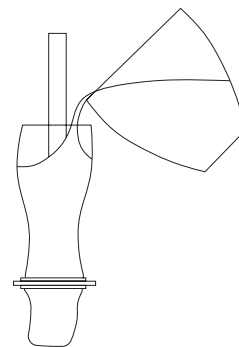

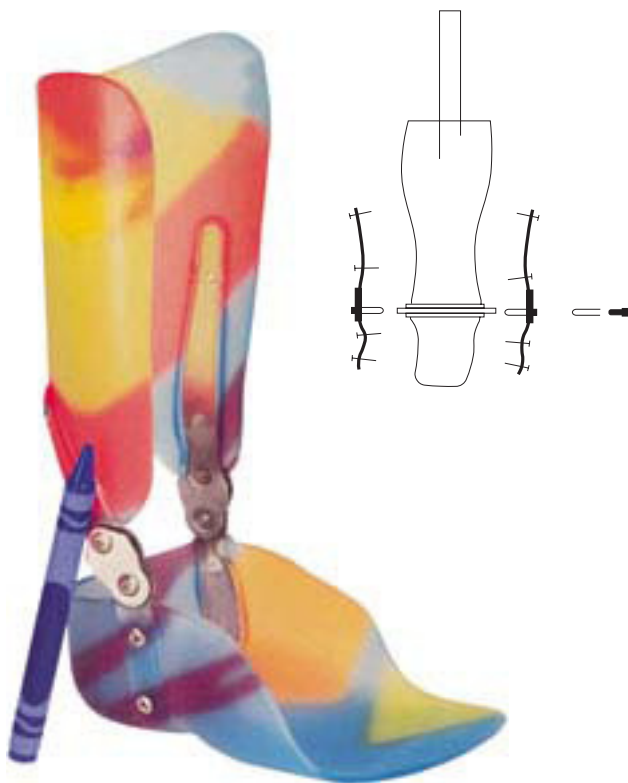
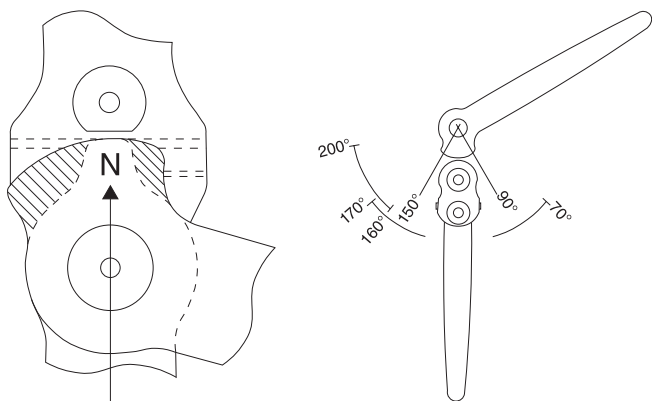
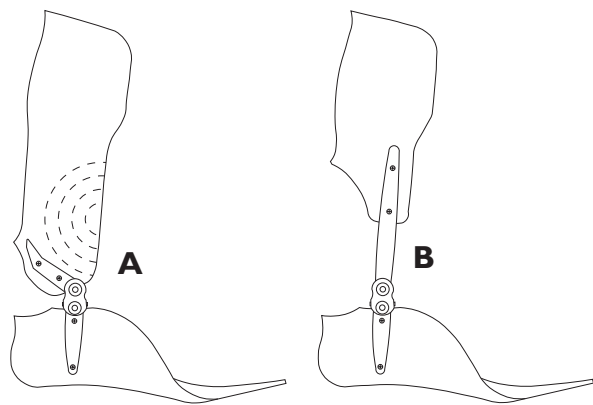

## 2. Select Proximal Joint Section

**A.** Curved uprights are recommended when pulling plastic over joints. Upright is prefabricated to limit either 50° of plantarflexion or 50° of dorsiflexion. Tooth notch may be cut to limit desired ROM in either direction.

- Curved style offers improved cosmesis
- Allows heat adjustability to thermoplastic at distal tibial region during fit / delivery
- Set tooth notch to desired ROM
- Contour uprights to desired position (proximal and posterior)
- Disassemble straight hinge and replace with curved joint section

**B.** Straight joint kits are best suited when applying joints externally, after thermoforming

- Fabricate AFO as usual
- Attach hinges in desired location using enclosed screw or rivets

## 3. Prepare Joints for the Modified Positive

- Remove the 5mm pin from the ankle joint axis and the mark medial and lateral joint position.
- Remove the center screw from each joint. Replace with a hexagon mounting screw and apply mounting piece to threaded end of screw.
- Trim uprights to desired length and contour to the cast. Maintain appropriate clearance at ankle joints. The joints must be parallel in order to function properly.
- Drill holes in uprights for attachment to positive and ultimate securing to orthosis.

## 4. Apply Joints to the Modified Positive

- Apply nylon stockinet to positive, in preparation for vacuu-forming.
- Secure hinges to positive with nails or spacers.
- Fill hollow spaces with heat resistant clay.
- Thermoform as usual.